



Dynamic Loudspeaker

36×22×5.4 mm

Guts

With waterproof IPX5

CR3622S054YN8WPZ

Revision

Date	Version	Status	Changes	Approver
2025/11/13	V0.1	Draft	First release	AX

Parameter	Conditions/Description	Values	Units
Rated Input Power	in 11CC BOX	2.0	W
Max Input Power	in 11CC BOX	2.5	W
Rated Impedance	1V input	8±15%	Ω
Rated Impedance	DCR	7.1±15%	Ω
Sound Pressure Level (S.P.L.)	2.0W/0.1M at 2K Hz Average .in 11CC BOX With Baffle	107±3	dB
Resonant Frequency	At 1V in 11CC BOX	750±20%	Hz
Frequency Range	Output S.P.L. -10dB	F0-10k	Hz
Distortion	at 1KHz, input 2.0W, in 11CC BOX With Baffle	< 5%	
Magnet	NdFeB		
Buzz, Rattle, etc.	must be normal at sine wave between 300 ~ 5kHz, in 11CC BOX	4.0	V
Polarity	cone will move forward with positive dc current to "+" terminal		
Weight			g
Operating		-40~+70	°C
Storage Temperature		-40~+85	°C
WaterProof	膜片面防水	IPX5	
Air Leak Test	音膜面防水,设置气压: 11.5-13.5KPa, 充气时间 2S,稳定时间 2S, 测试时间 5S, 泄露≤40Pa	IPX5	

Notes: Above Measuring condition under temperature :15~35°C R.H. 25~75%. Accordig to standard GB/T9396-1996

MECHANICAL DRAWING

Units: mm
Tolerance: ±0.2mm

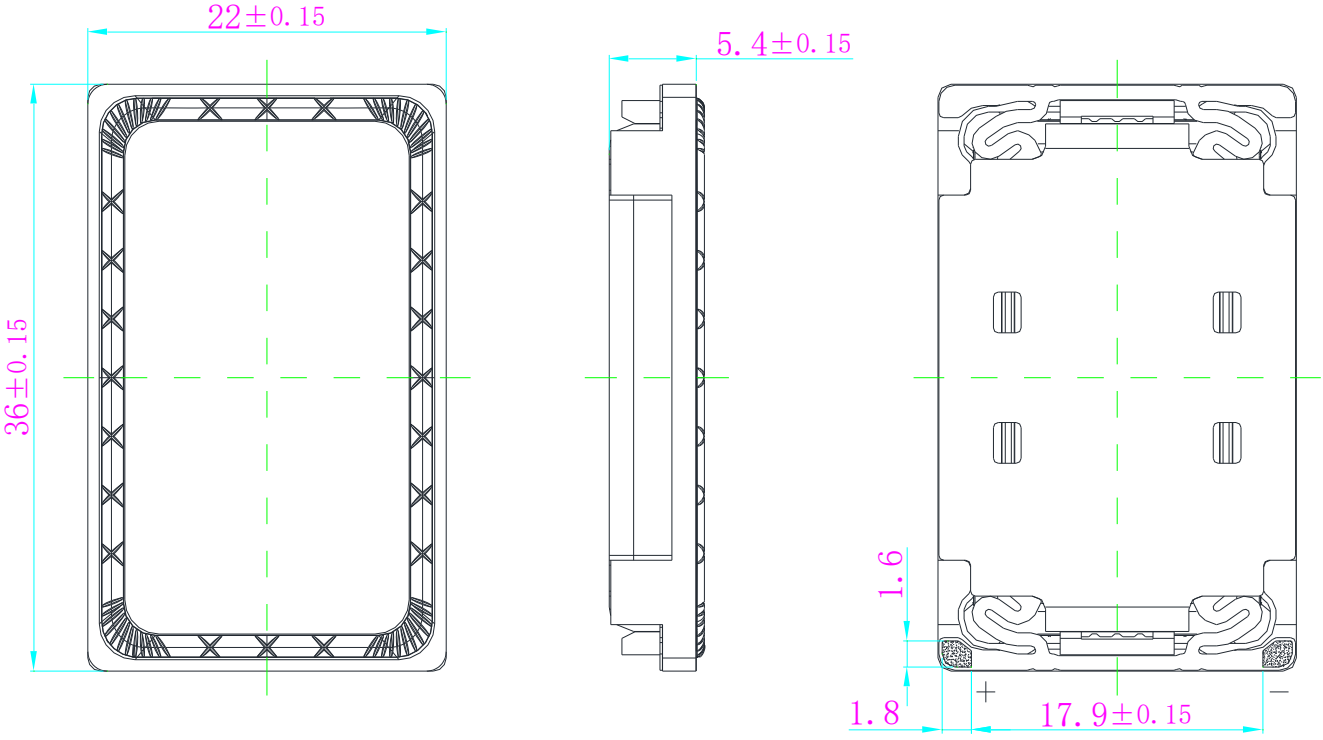

CONSTRUCTION DETAIL

7	FRONT CAP		SUS	1
6	VOICE COIL		COPPER WIRE	1
5	DIAPHRAGM		PEEK	1
4	U YOKE		SPCC	1
3	POLE PIECE		SPCC	1
2	MAGNET		NdFeB	1
1	FRAME		PPA	1
PART NO.	PART NAME	Q'TY	MATERIAL	REMARK

RESPONSE CURVES

Frequency Response Curve

Test condition: 2.0W/0.1M With Baffle in 11CC BOX

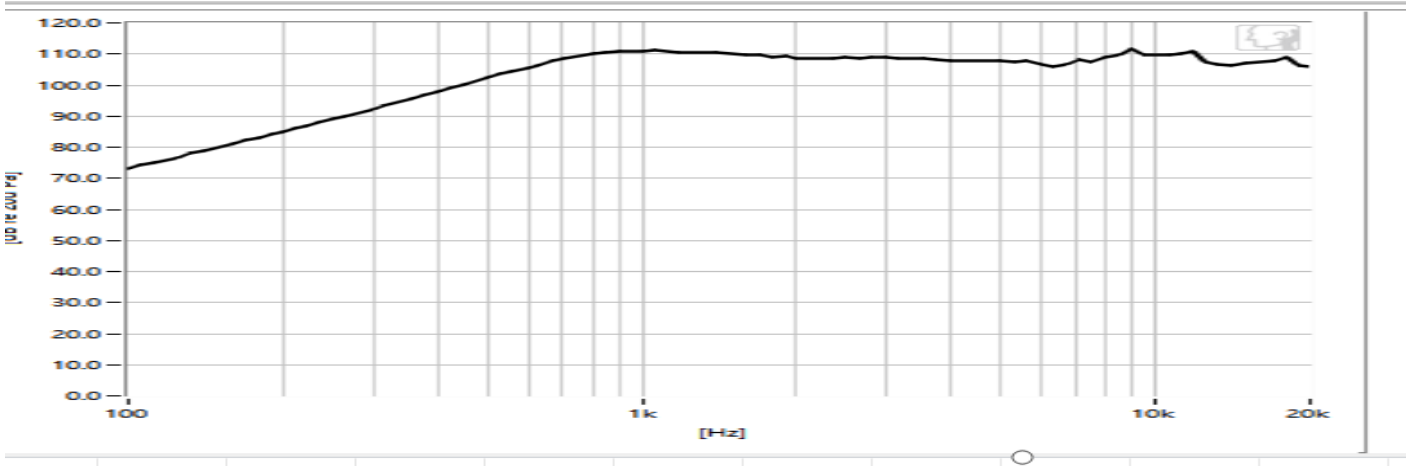

THD

Test condition: 2.0W/0.1M With Baffle in 11CC BOX

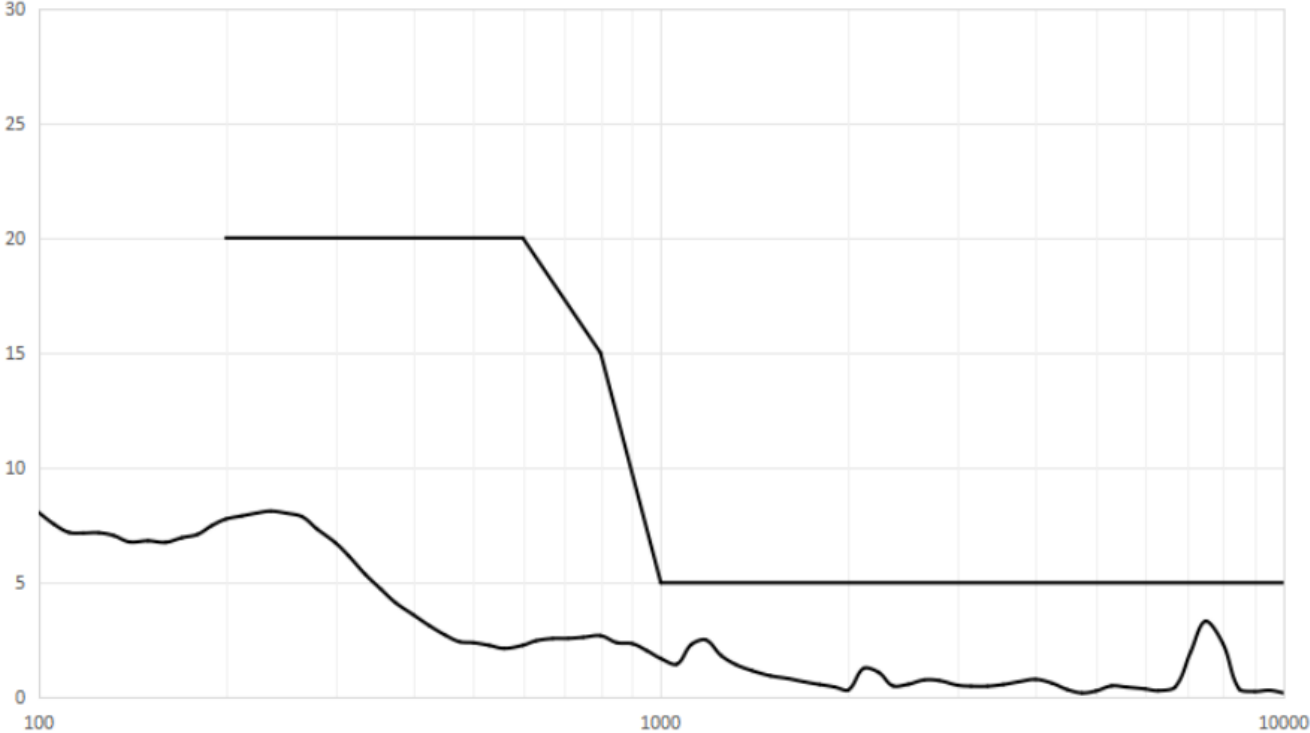

RELIABILITY TEST

1	Reliability Test Performance	After any following test, parts should conform to original performance within ± 3 dB tested with Rated Power, after 6 hours of recovery period.(with Test Signal: Pink noise crest factor=6, High-Pass filter: 12dB/Oct, -3dB@Fb)
2	Long-term rated power test	Input rated power pink noise to the speaker, low temperature ($-40\pm 2^{\circ}$) for 24hrs, then raising temperature to ($70\pm 2^{\circ}$) for 72hrs
3	Short-term maximum power test	Room temperature 25°C Input 1sec Max power pink noise to the speaker, idle for 59sec, cycling 30times.
4	Voice coil destructive test	(1) Before testing, Please use multimeter to measure the sample' s DC resistance and use X-Ray to check the voice coil, it must meet specification and not be broken, scattered, deformed and short-circuited. (2)Room temperature 25°C Input Max power DC Signal for 30sec. 5Pcs for normal connection(Power+ \rightarrow Speaker+, Power- \rightarrow Speaker-) 5Pcs for inverse connection(Power+ \rightarrow Speaker-, Power- \rightarrow Speaker+)

5	Voice coil destructive test II	<p>(1) Before testing, Please use multimeter to measure the sample' s DC resistance and use X-Ray to check the voice coil, it Must meet specification and not be broken, scattered, deformed and short-circuited.</p> <p>(2)Input Max power sweep signal to the speaker. Sweep frequency range: 300Hz to 20kHz Cycle time: 2Sec for one cycle, cycling for 8 hrs.</p> <p>(3) After test, measure sample' s DC resistance and use X-Ray to check whether the voice coil is scattered, deformed or short-circuited.</p>
6	Long-term temperature cycling test	<p>Input rated power pink noise to the speaker Temperature range: -40°C~70°C Temperature change rate is 5~10°C/min, 15min at -40°C and 70°C, cycling 50 times.</p> <p>1) Before testing, Please check appearance and acoustic performance, it must meet the specifications.</p> <p>(2) Put speaker into the middle of the test chamber, the distance between speaker and chamber inner wall is not less than 5cm</p> <p>(3) Check appearance and acoustic performance.</p>
7	Long-term high temperature and high humidity test	<p>Input rated power pink noise to the speaker Temperature 70°C, humidity 90%RH for 72hrs.</p> <p>(1) Before testing, Please check appearance and acoustic performance, it must meet the specifications.</p> <p>(2) Put speaker into the middle of the test chamber, the distance between speaker and chamber inner wall is not less than 5cm</p> <p>(3)Cooling down to room temperature 25 °C, 2hrs, then check the appearance and acoustic performance.</p>
8	High temperature and high humidity test	<p>Input rated power pink noise to the speaker Temperature 85°C, humidity 90%RH for 6hrs.</p> <p>(1) Before testing, Please check appearance and acoustic performance, it must meet the specifications.</p> <p>(2) Put speaker into the middle of the test chamber, the distance between speaker and chamber inner wall is not less than 5cm</p> <p>(3)Cooling down to room temperature 25 °C, 2hrs, then check the appearance and acoustic performance.</p>

9	Salt mist test	<p>Salt mist concentration: 5% NaCl PH: 6.5~7.2 solution, which was continuously sprayed at 35 ° C for 48 hours.</p> <p>(1) Put into salt mist chamber and do not overlap each test speaker, sample shall be supported or suspended between 15 and 30° C from the vertical and preferably parallel to the principal direction of flow of fog through the chamber, based upon the domaint surface being tested</p> <p>(2)Continuously spray NaCl solution into the test chamber for 48 hours.</p> <p>(3)After this test, taken out the sample and washed this sample carefully to remove the residual NaCl solution on the surface.</p>
10	Drop test	<p>Mounted in a special fixture, all the speaker module or drive should be in a small plastic box.</p> <p>Sample size: 5 for Plywood over concrete, 5 for Concrete.</p> <p>Height of the drop: 160cm</p> <p>Surface: 2" Plywood over concrete and Concrete</p> <p>Drop sequence: Six faces</p> <p>Standard: EN 60068-2-31</p> <p>(1) Before testing, Please check appearance and acoustic performance, it must meet the specifications.</p> <p>(2) Check appearance and acoustic performance.</p>

MEASURING METHOD

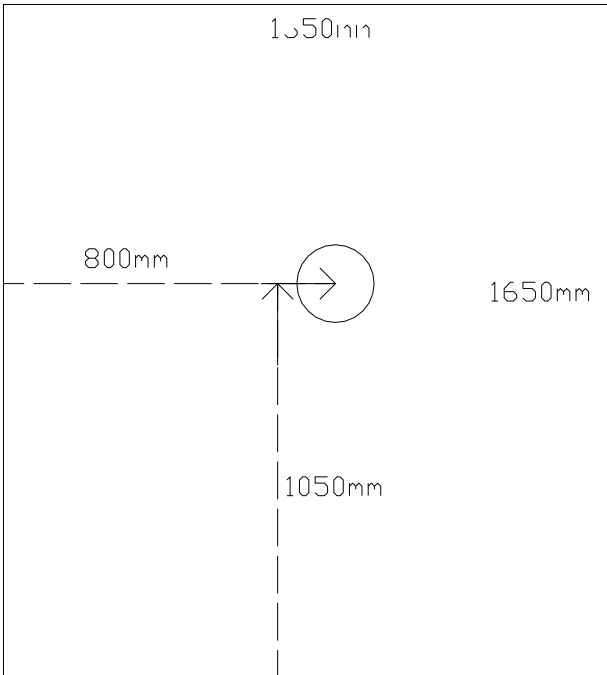

Fig. 1 Block Diagram for Measurement Method

Standard test condition of speaker

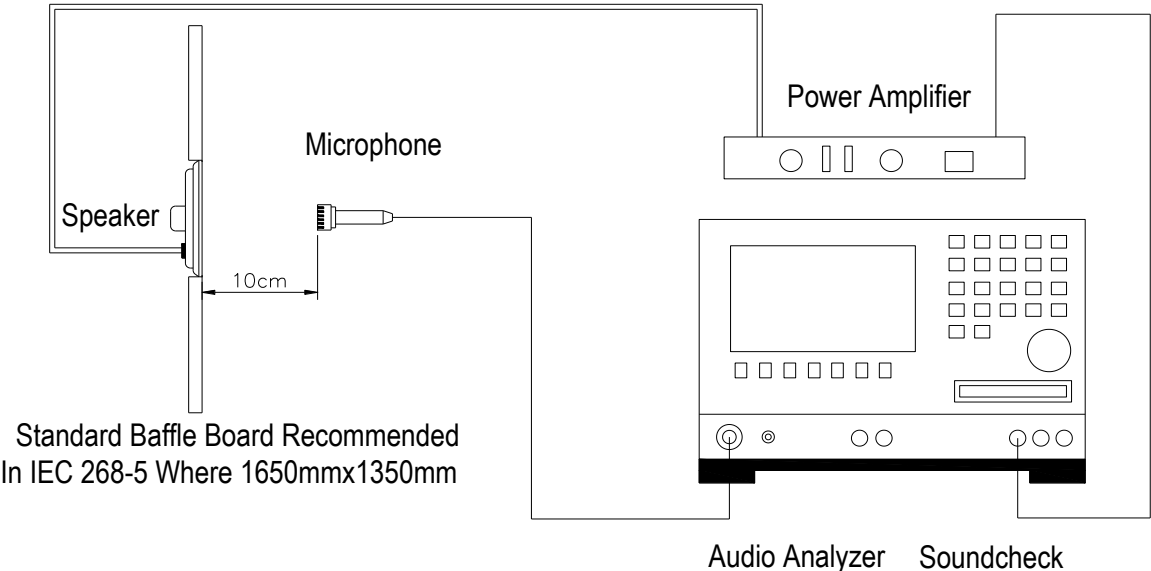

Fig. 2 Speaker Test Condition

PACKAGING

Storage conditions:

Speakers should be well packed.

The temperature should be as stable as possible and between -10° C and +40° C.

The relative humidity should be below 90%.

There should be no acid or other harmful gases in the surrounding air (GB/T 9397—200X)

每盘 45 个 45pcs of speaker in each tray

每箱 20 盘 20 trays in one carton

总计:450 个 / 1 箱 Total:450 pcs / 1 carton

毛重: 10.8KGS Gross Weight:10.8KGS

净重: 9.1KGS Net Weight: 9.1KGS

